



SUBARU

*INSTALLATION
INSTRUCTIONS*

SUBARU

PART NUMBER: E551SAJ100

DESCRIPTION: OUTBACK FRONT UNDER GUARD

KIT CONTENTS:

A.



Front Under Guard x 1

B.



Push Retainer x 4

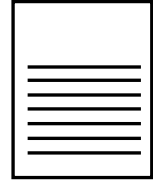

Installation
Instructions x 1

C.

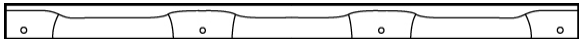

Installation Fixture x 1

D.



Alcohol Wipe x 2

TOOLS REQUIRED:

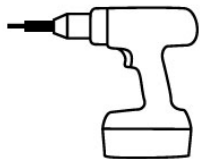

Drill with 1/8" Drill Bit
and 1/2" Drill Stop

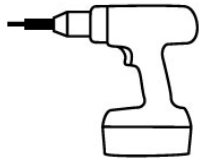

Drill with 1/4" Drill Bit
and 1/2" Drill Stop

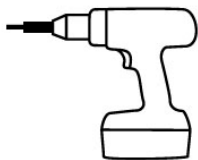

Drill with 5/16" Drill Bit
and 1/2" Drill Stop



Bessey 4" deep reach
Ratcheting clamp
Part No. XCRU5
(or similar)

PART NUMBER:
E551SAJ100

ISSUE:
2

DATE:
11-19-13

SUBARU OF AMERICA

PAGE
1/4

MEANING OF CHARACTERS:

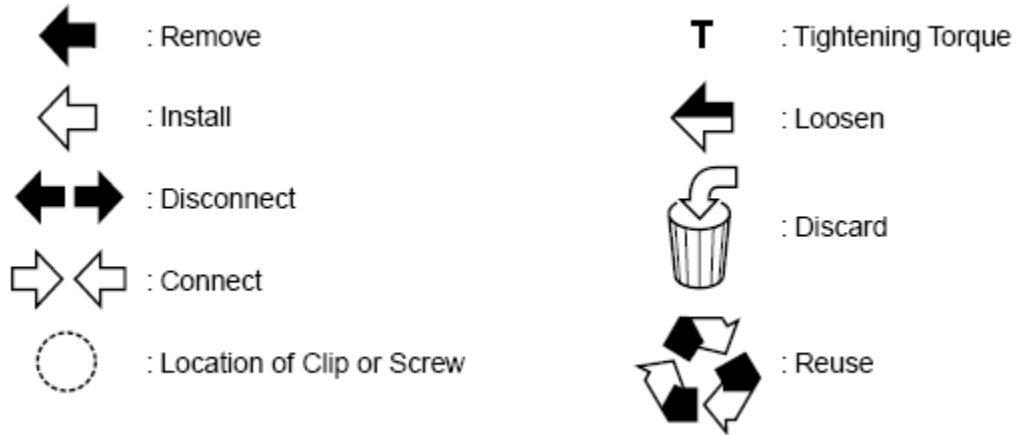

Surface Preparation

1

Make sure that all installation surfaces (shown below) are clean, free of dirt, grease, and debris. If necessary, use a clean, lint-free cloth and isopropyl alcohol based cleaner. Inspect vehicle for damage before installation of front bumper under guard. Before beginning, vehicle and under guard must be at room temperature. If the temperature is below 60 F (16 C) or above 110 F (43 C), let vehicle sit indoors until the bumper and under guard are room temperature

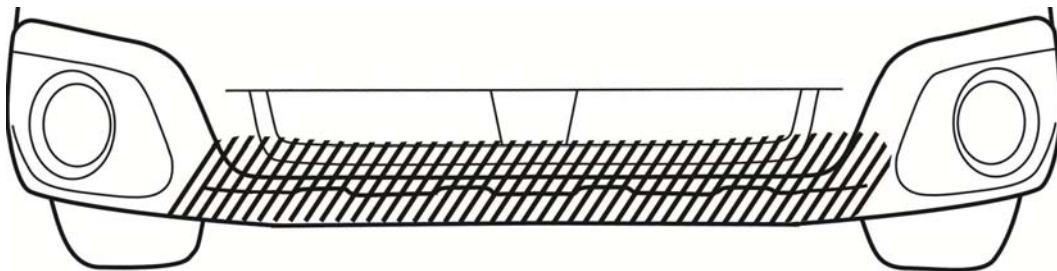

Front Molding Installation

2

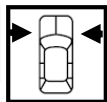

Align and position installation fixture.

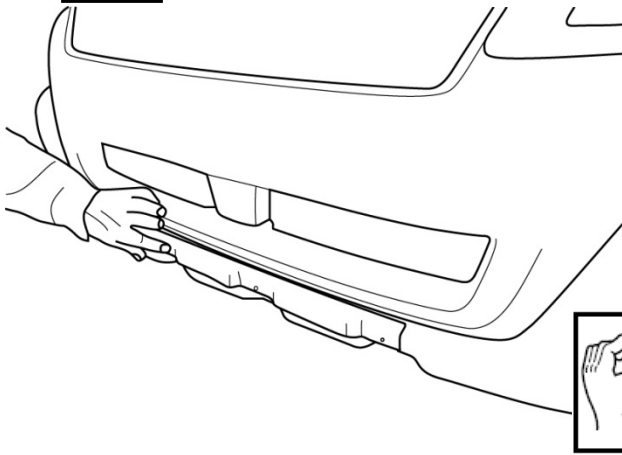

3

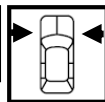

Drill four 1/8" mounting holes at indicated locations on the installation fixture.

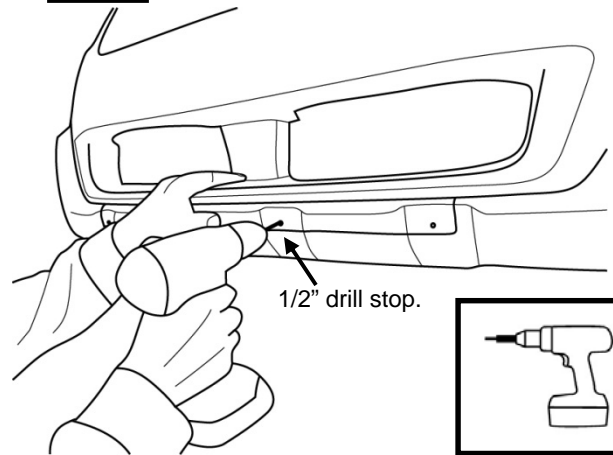

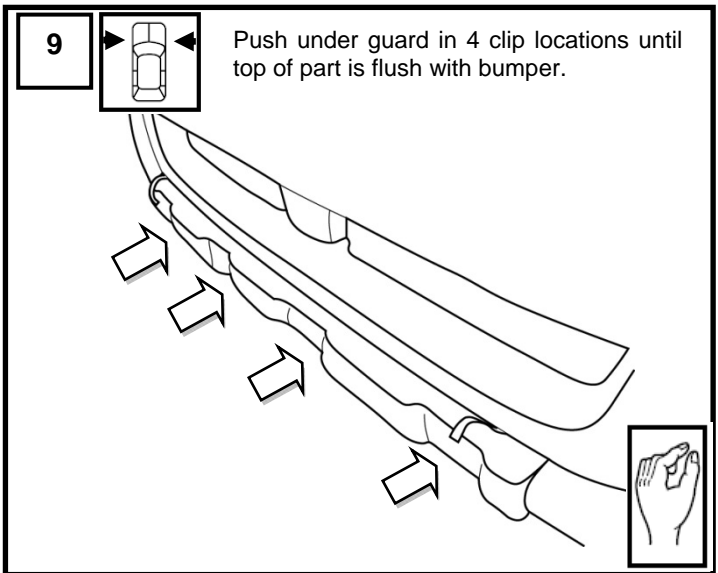
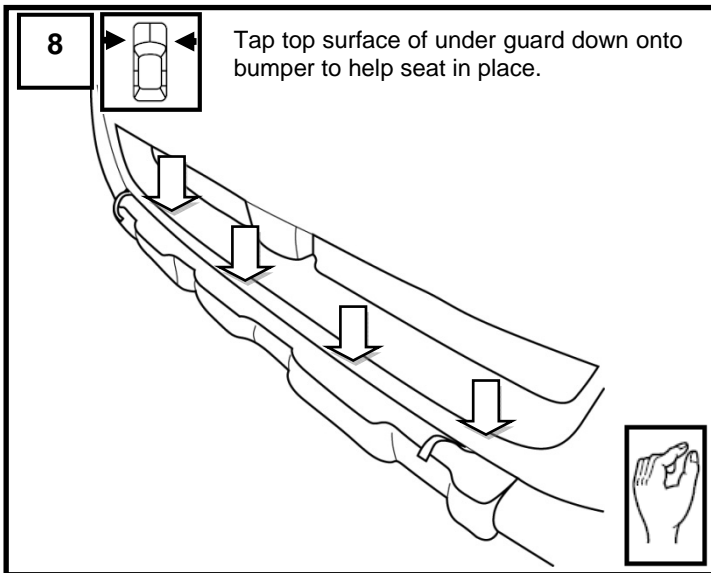
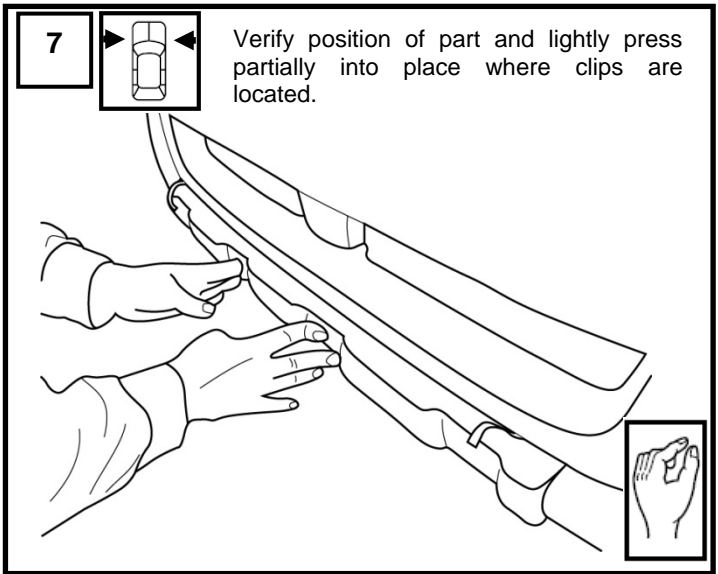
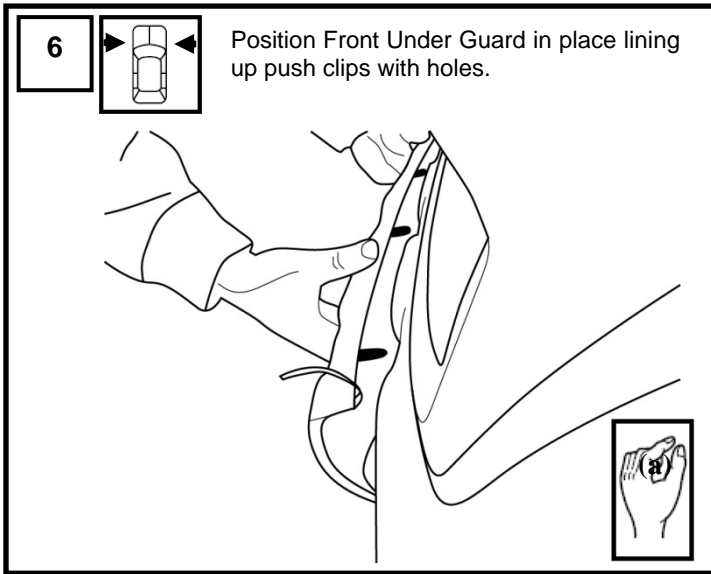
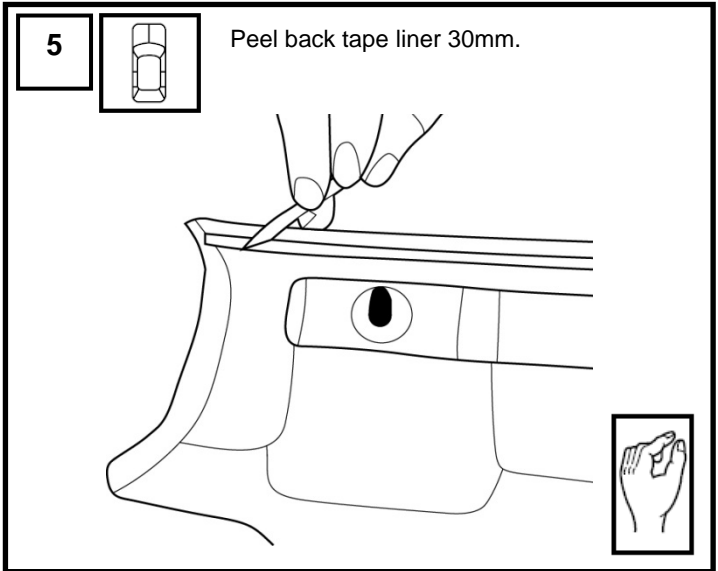
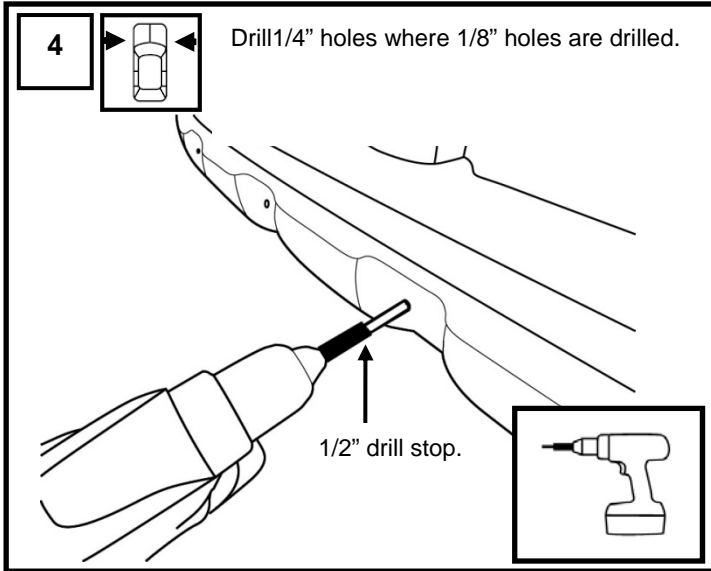

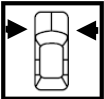
10  Use clamps to hold part against bumper. When properly positioned, the inside legs of clamps should be directly beneath but not touching Christmas tree fasteners at each end.

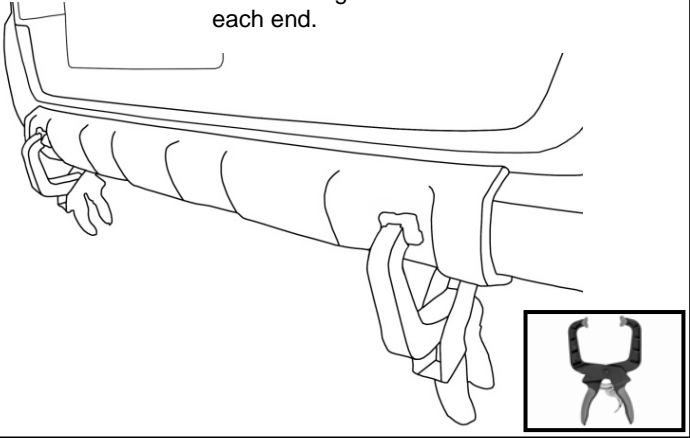

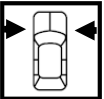
11  With clamps in place, using 5/16" drill bit, drill (5) 5/16" mounting holes through the existing holes in the underside of the part and through the bumper.

1/2" drill stop.

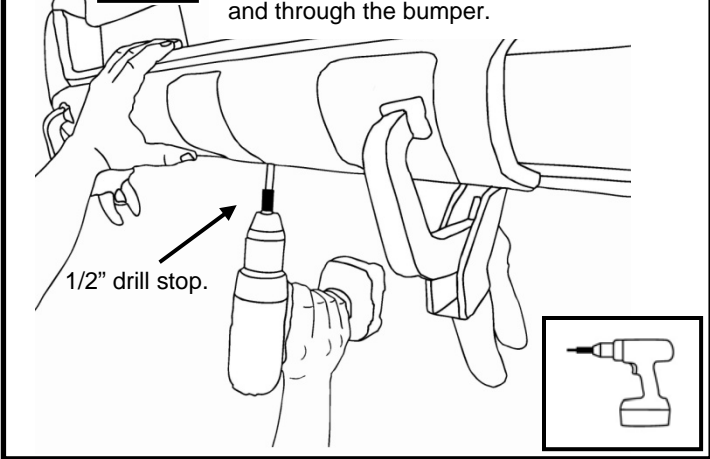

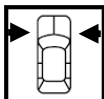
12  Pull tape liner. Press part against bumper to adhere tape applying 30 psi of pressure for a minimum of 10 seconds. Allow 24 hours for maximum bond.

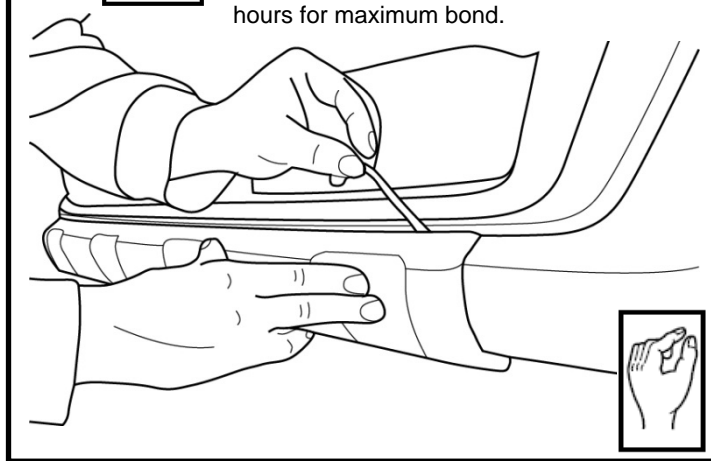

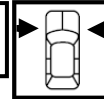
13  Remove clamps and install push retainers through holes in underside of part and into vehicle.

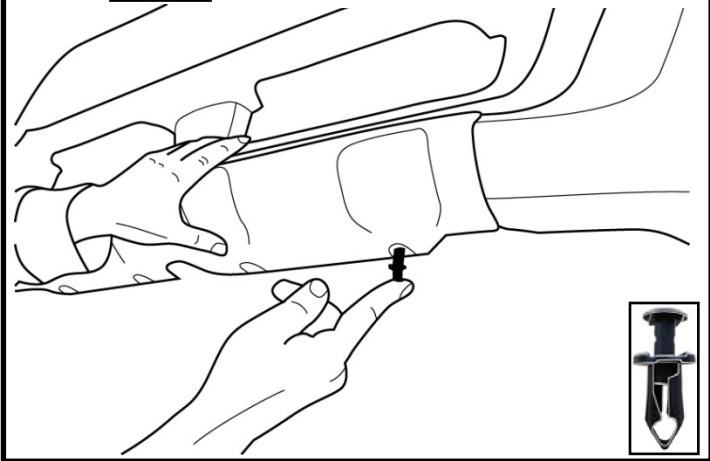

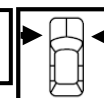
14  Installation complete.

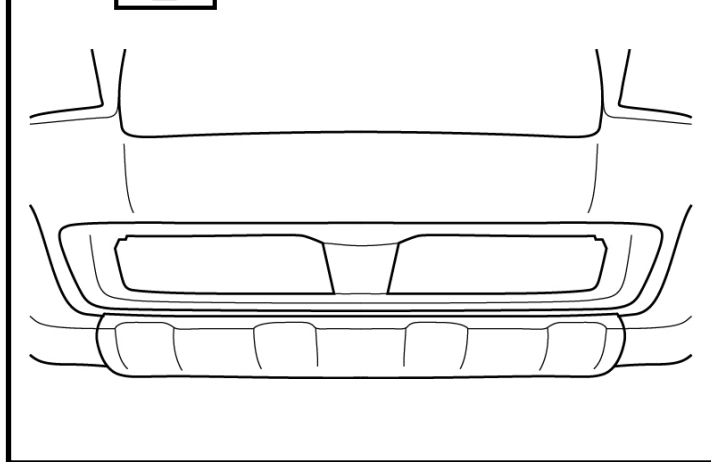



SUBARU

**INSTRUCTIONS
D'INSTALLATION**

SUBARU

NUMÉRO DE PIÈCE : E551SAJ100

DESCRIPTION : ÉCRAN INFÉRIEUR AVANT DE LA OUTBACK

CONTENU DE LA

A.

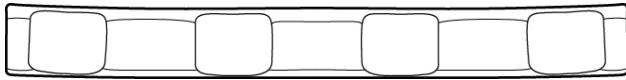

Écran inférieur avant x 1

B.



Cheville x 4

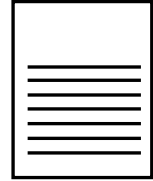

Instructions x 1

C.

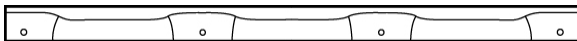

Support d'installation x 1



Lingette imbibée d'alcool x 2

OUTILS REQUIS :

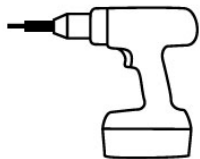

Perceuse avec mèche de 1/8 po et butée de perçage de 1/2 po

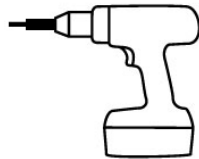

Perceuse avec mèche de 1/4 po et butée de perçage de 1/2 po

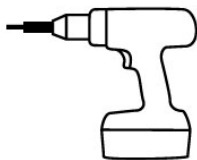

Perceuse avec mèche de 5/16 po et butée de perçage de 1/2 po



Bessey 4 "portée profonde Ratcheting pince réf. XCRU5 (ou similaire)

NUMÉRO DE PIÈCE :
E551SAJ100

VERSION :
2

DATE :
2013-11-19

SUBARU OF AMERICA

PAGE
1/4

SIGNIFICATION DES SYMBOLES :

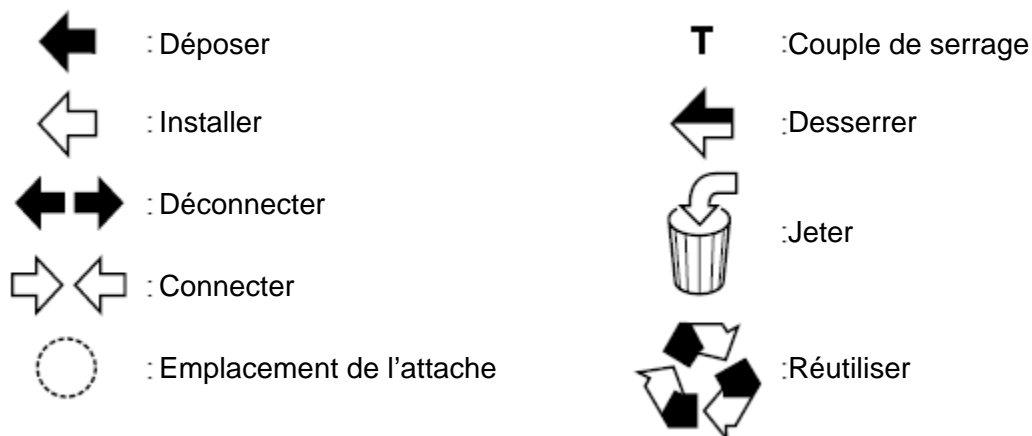

Préparation de la surface

1

Assurez-vous que les surfaces de montage (montrées ici) sont propres, sans tache, graisse ou résidu. Au besoin, utilisez un chiffon propre non pelucheux et un nettoyant à base d'alcool isopropylique. Inspectez le véhicule pour déceler toute trace de dommage avant de poser l'écran inférieur de pare-chocs avant. Avant de commencer, veillez à ce que le véhicule et l'écran inférieur soient à la température ambiante. Si la température est inférieure à 15,5 °C (60 °F) ou supérieure à 43 °C (110 °F), laissez le véhicule reposer à l'intérieur jusqu'à ce que le pare-chocs et l'écran inférieur soient tous deux à température ambiante.

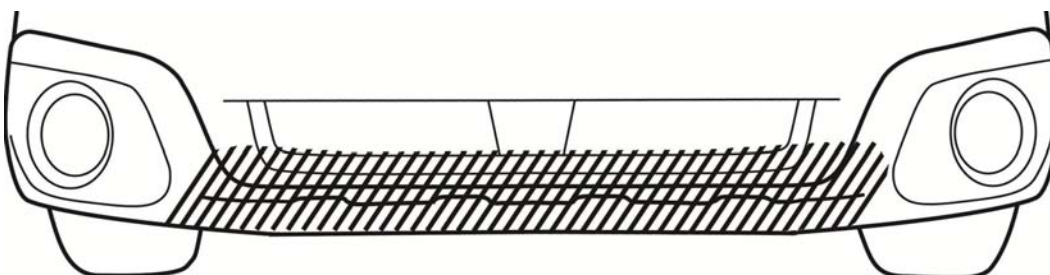

Installation de la moulure avant

2

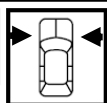

Alignez et placez le support d'installation.

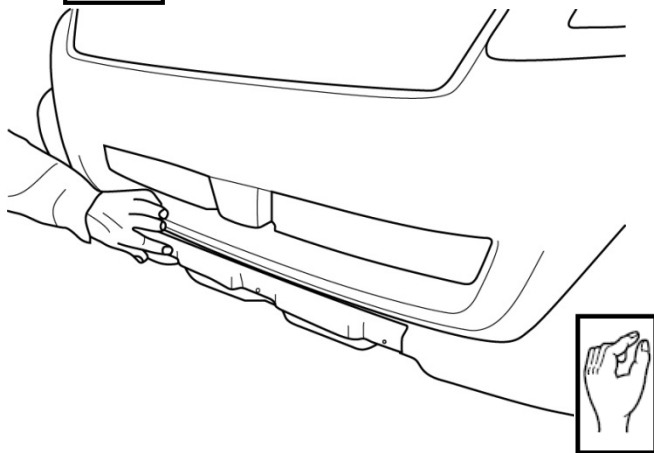

3

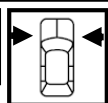

Percez quatre orifices de montage de 1/8 po aux endroits indiqués sur le support d'installation.

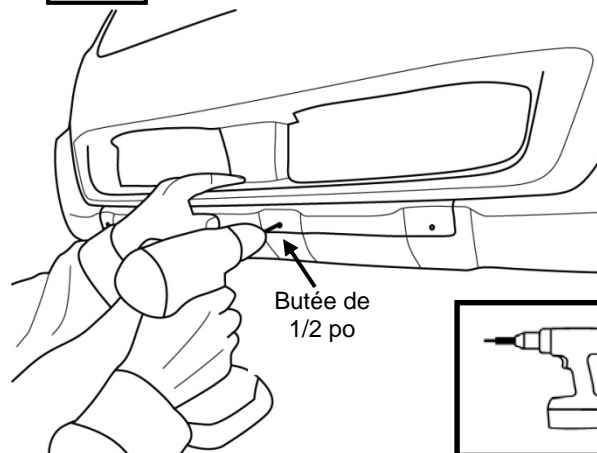

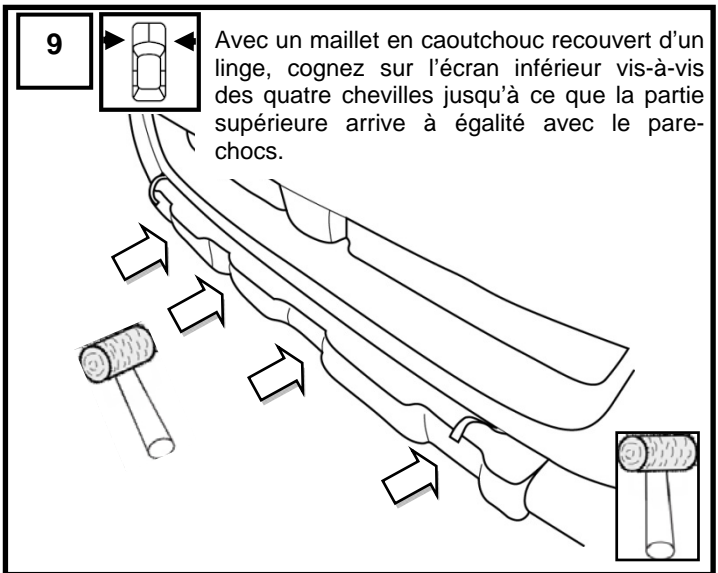
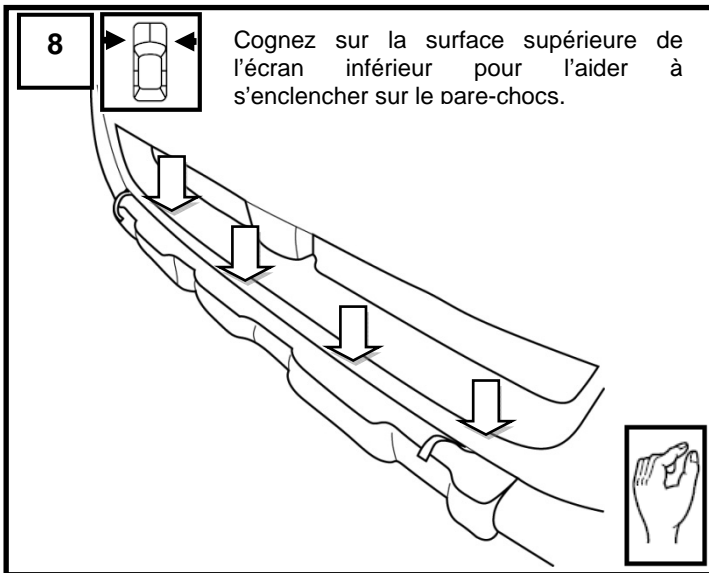
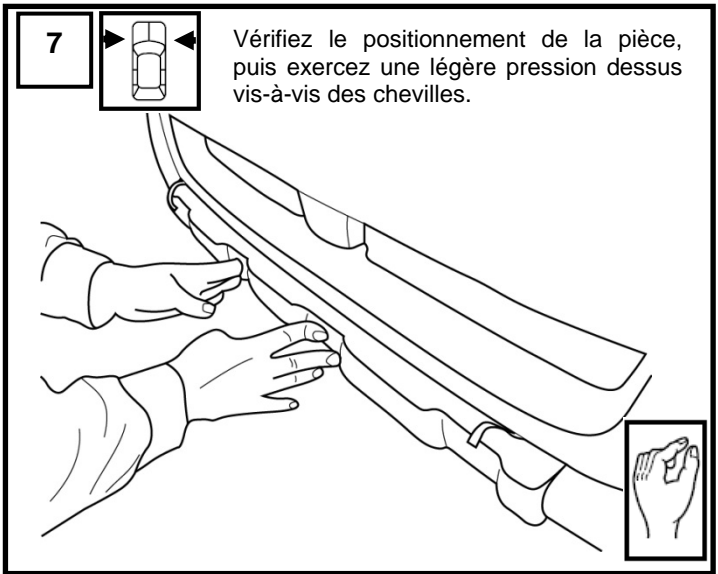
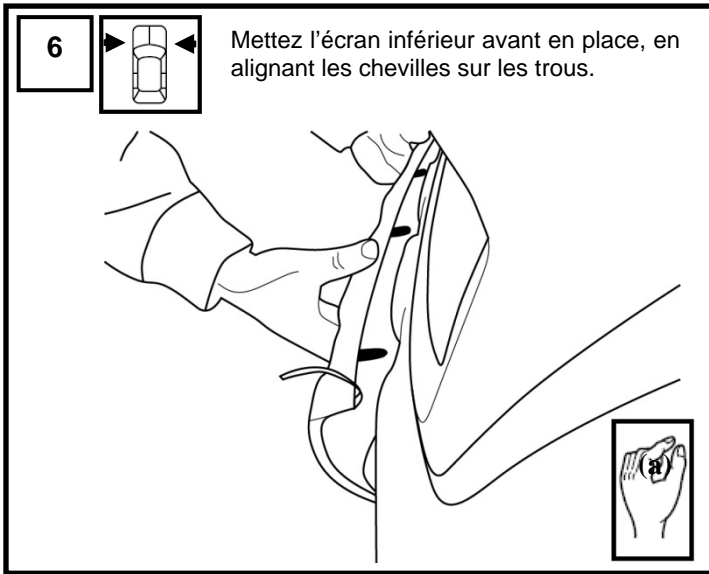
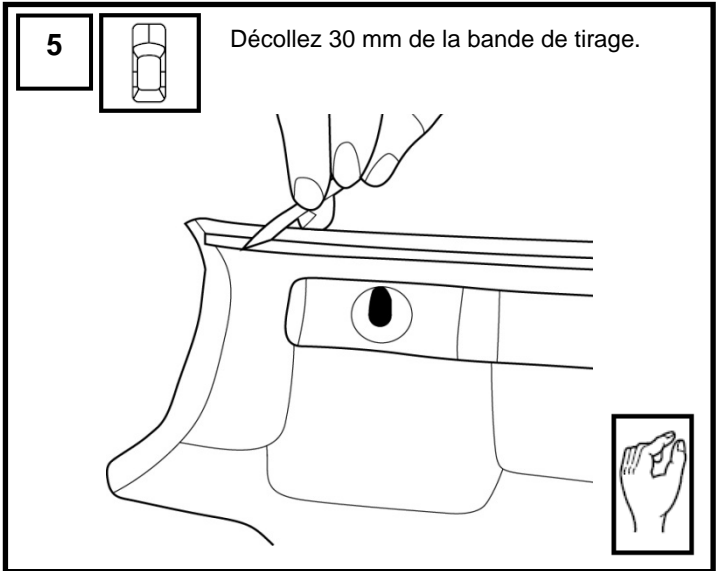
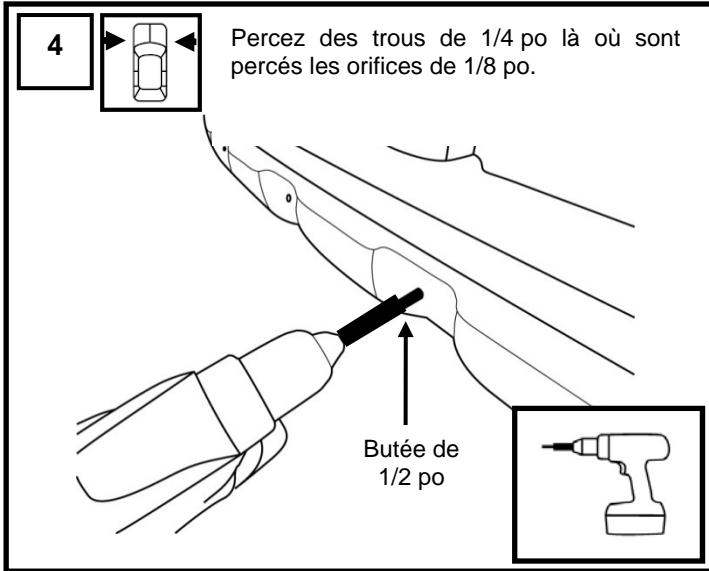

10

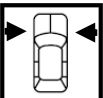

Utilisez des attaches pour tenir la partie contre pare-chocs. Lorsque correctement positionné, l'intérieur, pattes de serrage doivent être juste en dessous, mais sans le toucher Noël arbre attaches à chaque extrémité

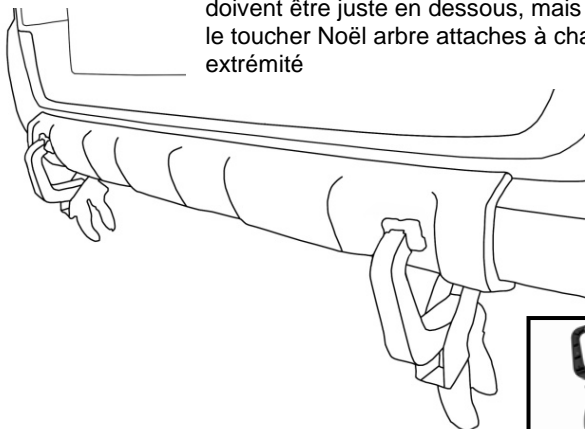

11

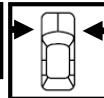

Décolliez la bande de tirage. Exercez une pression de 30 lb-pi² sur la pièce appuyée contre le pare-chocs pendant au moins 10 secondes pour faire coller l'adhésif. Prévoyez 24 heures pour que l'adhésif atteigne sa pleine puissance.

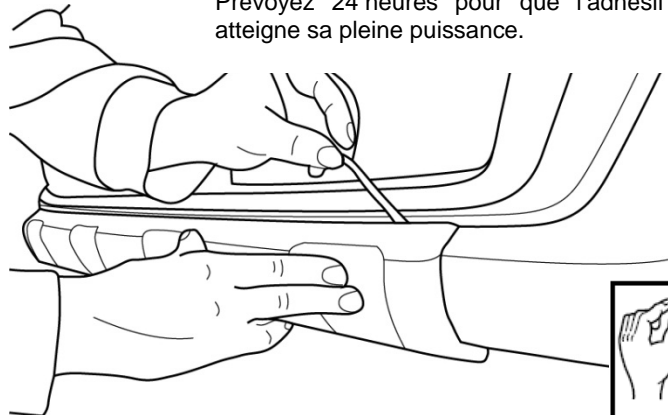

11

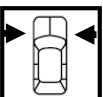

En appuyant fermement sur la pièce pour la maintenir contre le pare-chocs afin de prévenir la formation d'interstices sur les côtés, percez des trous sur la paroi inférieure de la pièce jusque dans le véhicule avec une perceuse dotée d'une mèche de 5/16 po et d'une butée de 1/2 po.

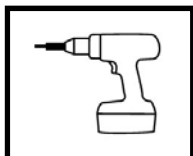
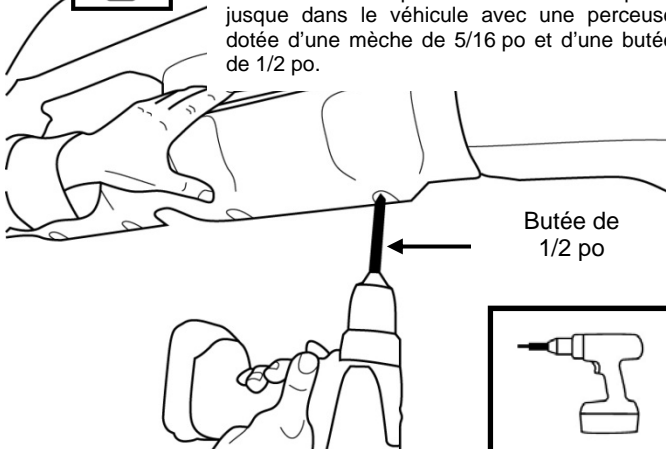

12

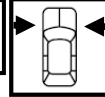

Posez les chevilles dans les trous percés sous la pièce, jusque dans le véhicule.

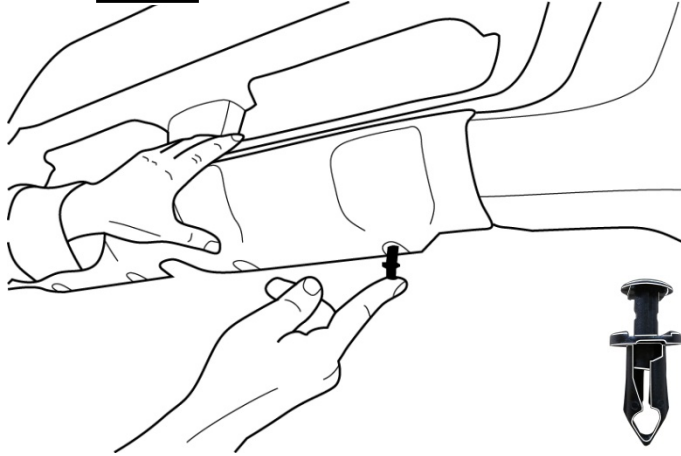

13

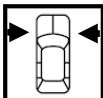

L'installation est terminée.

